

T-PLATE B OIL HEAT EXCHANGERS FOR FLUID HANDLING APPLICATIONS

Advantages of TEMPCO T-Plate B oil

Compactness

T-Plate B oil occupy an extremely small volume, sometimes down to 1/10 of the space occupied by other exchangers types. This advantage is highly valuable especially for prefabricated systems.

Thermal Performance

The unique computer designed plate pattern on TEMPCO oil coolers causes the liquid to flow in fully developed turbulence and in true counter-current flow.

Turbulent flow will be maintained also at very low velocities, giving extraordinary high film coefficients, also for viscous medias. This results in overall heat transfer coefficients three to five times higher than achievable in an S&T type heat exchanger.

High Thermal Efficiency

The extreme efficiency in TEMPCO oli coolers opens up new possibilities in designing oil cooling systems. This efficiency allows the exchanger to operate with very close temperature differences, so there are new possibilities in heat recovery and the running cost for cooling water usage is reduced.

Oil coolers are traditionally designed with a 1:1 or 1:2 water/oil flow ratio; with TEMPCO oil coolers, 1:5 or even 1:10 ratios are economical.

The criteria for choosing between air cooled and water cooled are thus been changed.

High Working Pressure

The unique design of TEMPCO T-Plate B oil, where the exchanger is brazed all around the edges as well as in every contact point all over the heat transfer surface, insures high resistance towards pressure pulses and static pressure. Every single exchanger is pressure tested to 40 bar before shipment; for special purposes burst tests to 200 bar are possible.

High Quality Material

TEMPCO T-Plate B oil consist of stainless acid resistant plates, AISI 316, brazed together with 99,9% pure copper. The material ensures excellent corrosion resistance, even in poor water conditions.

Design Flexibility

TEMPCO offers seven different plate sizes to meet your special needs. The plate number will be customized according to you request.

Low Pressure Drop on Water Side

Since the TEMPCO T-Plate B oil can operate with very high efficiency also at low velocities, the exchanger can be selected for low pressure drop on the water side, without losing efficiency.

Low Weight

Compact execution and small hold-up volume mean that TEMPCO T-Plate B oil's weight is only a fraction of other exchangers' weight.

Modularity

T-Plate B oil can be easily arranged in batteries for systems built on modules.

Identical Products

In a T-PLATE B OIL, plates are pressed out of homogeneous steel and brazed together; these plates are pressed with the same tool every time, which guarantees that each plate is identical to the others.

It means that the heat exchanger will always perform exactly the same. This is a great difference to many S&T heat exchangers, where great variances in execution may exist.

Economy

In many cases, T-PLATE B OIL does represent the most economical solution for the customer. This depends on the T-PLATE B OIL purchase price, many times lower than that of other heat exchangers. Moreover, due to easier unit mounting, savings can also be made on smaller casings, packing and transportation.

TEMPCO T-Plate B oil Applications

Oil cooling main purpose is to reject heat excess, control operating temperature and maintain oil quality.

Typical applications for TEMPCO oil coolers are:

- hydraulic systems, power packs
- air compressors, heat recovery
- lube oil systems
- transformer oil
- fluid couplings
- Diesel engine, oil coolers
- quench oil cooling
- general industrial, hydraulics, oil cooling

Other applications where T-PLATE B OIL can be used are:

- refrigeration systems – oil coolers, condensers, evaporators
- HVAC systems – district heating, boilers
- heat recovery

TEMPCO T-Plate B oil can be used for various media as:

- oils (synthetic or mineral)
- organic solvents
- water

Please note that demineralized water does not cause any problem, but if water is chemically treated you may contact us.

Sea water cannot be used in T-Plate B oil; for sea water applications, TEMPCO PHEs with titanium plates are recommended.

- glycol mixtures (ethylen-/propylen-glycol)
- refrigerants (except for ammonia, which cannot be used in TEMPCO T-Plate B oil)

Hydraulic Power Packs

Many power pack producers are now using TEMPCO T-Plate B oil as water cooled oil coolers.

Due to their high efficiency, TEMPCO units will be able to perform the same cooling capacity but utilizing a fraction of the water flow needed when using old technology.

Extreme compactness and ultra-light construction simplify the assembly and will also help to reduce the overall cost.

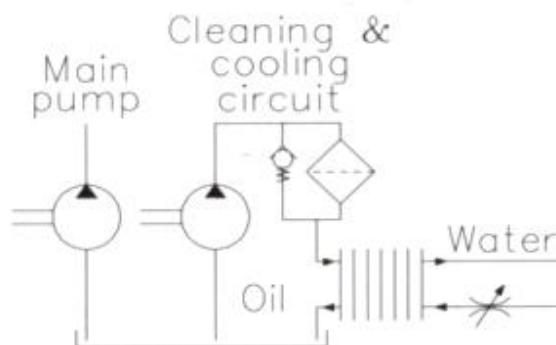

Air Compressor, Oil Cooling and Heat Recovery

The function of the screw compressor is based on oil cooling.

When oil is injected in the compression chamber, it absorbs the heat generated by compression.

More than 70% of the energy used in the compression process can be employed in producing hot water.

Energy quality can be described by leaving water temperature level. By using high efficient oil to water heat exchangers, the heat recovery quality can be significantly increased.

With the latest technology in heat transfer and the most efficient and compact oil cooler on the market, TEMPCO T-Plate B oil open up new possibilities in system design and heat recovery.

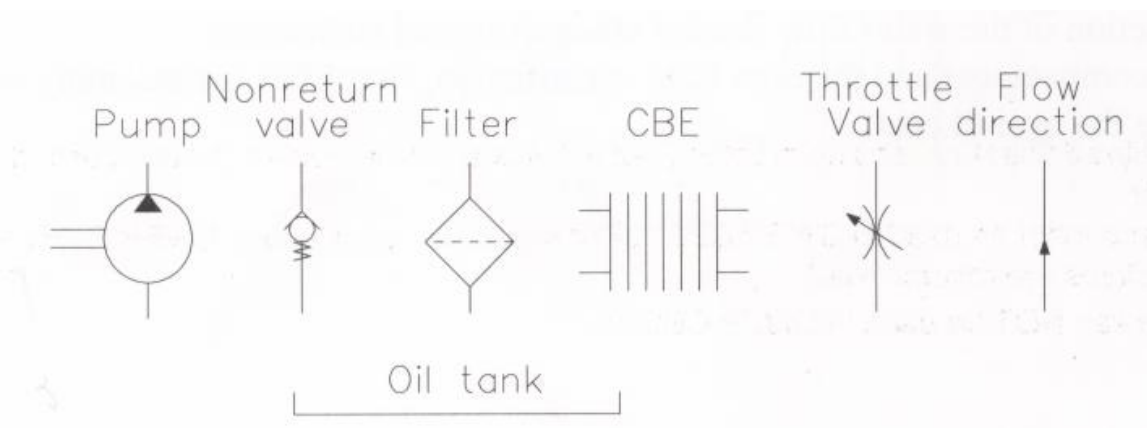
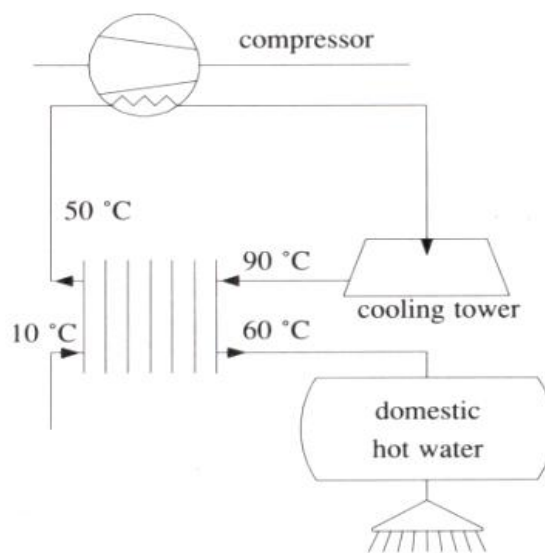

Lube Oil Systems

In circulating lubricating systems, where lubrication is controlled by oil viscosity, precautions have to be taken when designing the system.

The amount of oil passing through each lubricating device is controlled by a pressure drop. For viscous fluids, this amount is strictly depending on viscosity and temperature.

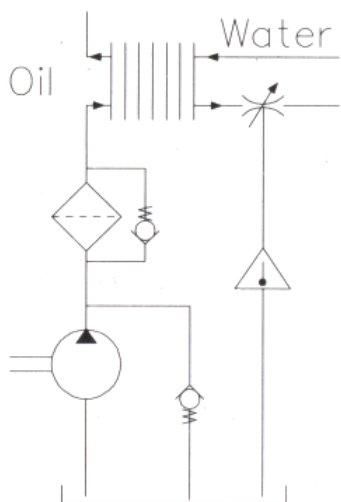

To be able to control lubrication, viscosity needs to be kept constant, meaning that output temperature has to be very accurate.

TEMPCO oil cooler has an extremely small holdup volume which allows the heat exchanger to react very fast on changes, both on the oil side and the water side. This gives a more reliable function, saves the production equipment that should be lubricated and, at the same time, it prolongs its lifetime.

TEMPCO T-Plate B oil high efficiency makes possible to maintain full cooling mode with extremely limited amounts of cooling water.

Fluid Coupling

Oil is used to create friction and, thereby, transferring mechanical energy. In this process, friction energy is converted to heat, absorbed by oil. To be able to maintain full control on fluid coupling, oil temperature has to be very accurately controlled, since oil viscosity has a great impact on power transmission.

TEMPCO oil cooler has an extremely small holdup volume which allows the heat exchanger to react very fast on changes, both on the oil side and the water side.

Due to their high efficiency, TEMPCO units will be able to perform the same cooling capacity but utilizing a fraction of the water flow needed when using old technology.

Extreme compactness and ultra-light construction simplify the assembly and will also help to reduce the overall cost.

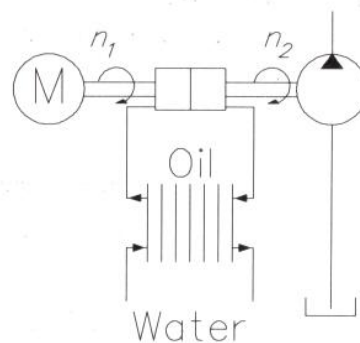

Diesel engines – Power Stations

In power plants where Diesel engine is used, there are many applications for plate heat exchangers.

Advantages in using TEMPCO heat exchangers are:

- compactness: space is often at a premium.
- materials: high quality materials are used. SS for fresh water and Ti for sea water.
- heat recovery: an high degree of heat recovery is possible when using TEMPCO high efficient heat exchangers.

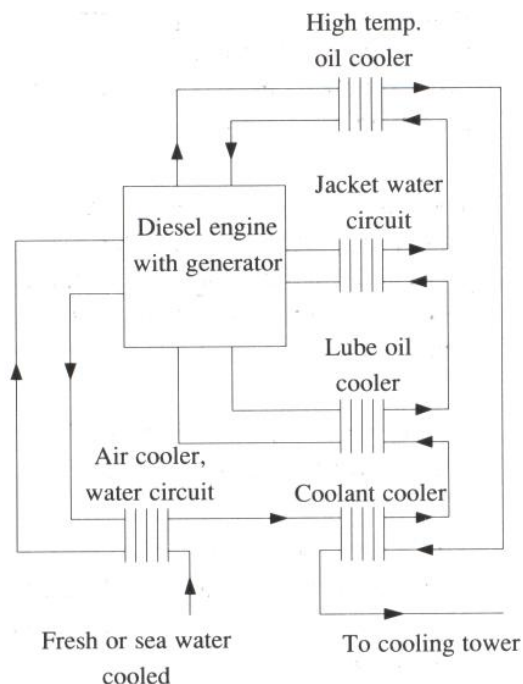

Diesel engines– Mobile applications

In mobile applications, component size and weight are critical. TEMPCO T-Plate B oil offer new possibilities to reduce those parameters because they are the most compact and efficient heat exchangers on the market.

Compared to other heat exchangers, they will give the same performance but with a fraction in weight and size.

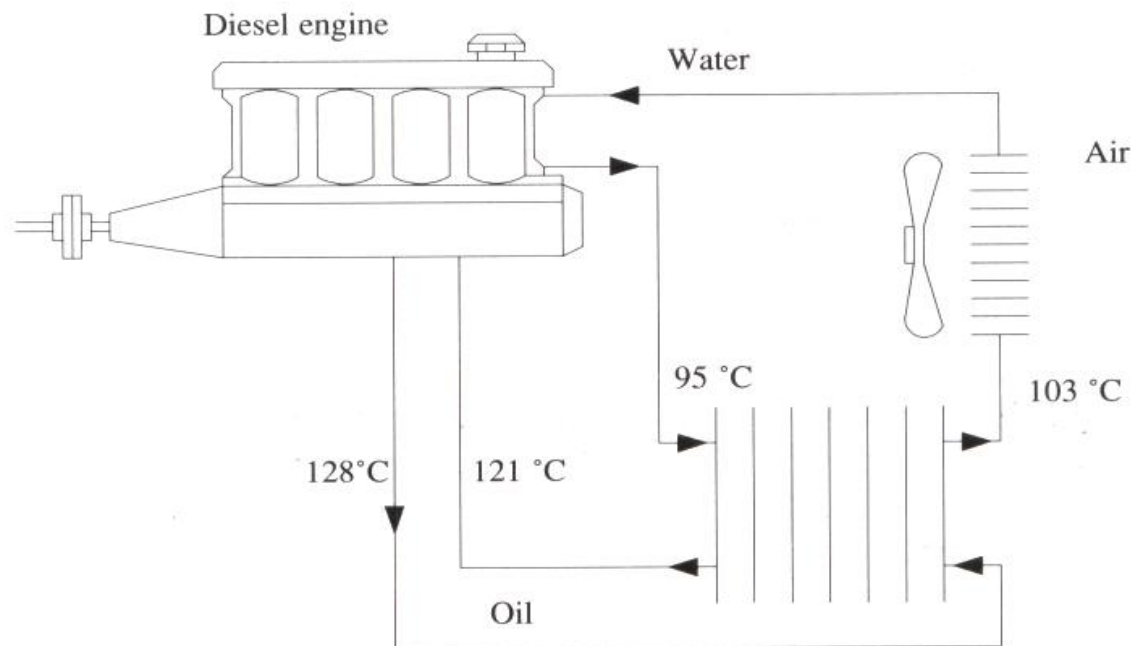

Questions and Answers about TEMPCO Oil Coolers – T-Plate B oil

What is a TEMPCO T-PLATE B OIL?

A compact brazed heat exchanger (T-PLATE B OIL) is a new type of heat exchanger by TEMPCO, for liquid to liquid and gas to liquid applications.

It consists of several acid proof stainless steel plates, embossed with an unique computer designed pattern. Plates are stacked with the pattern reversed on plate to plate. This forms a lattice of contact points and flow channels, that cause the fluid to flow in true counter current flow and with fully developed turbulence.

The result is the most efficient heat exchanger on the market.

Why do TEMPCO T-Plate B oil have such high performances?

The fluids flow within a TEMPCO T-PLATE B OIL follows the path created by the pattern embossed in the plates; this unique pattern causes the flow to continuous direction changes, keeping high turbulent flow all over heat transfer surface. In a conventional heat exchanger a stagnant film always develops, but here it's continuously broken down as the fluid passes through the T-PLATE B OIL.

This results in overall heat transfer coefficients three to five times higher than the ones obtainable in S&T type heat exchangers.

In oil cooling applications, this high performance could be translated in water consumption: by using TEMPCO oil coolers, water/oil flow ratios down to 1:10 are economical.

The criteria for choosing between air cooled and water cooled have thus been changed.

TEMPCO T-Plate B oil are smaller than other heat exchangers. How much smaller?

A typical comparison between a TEMPCO T-PLATE B OIL and a traditional S&T exchanger is that a TEMPCO T-PLATE B OIL can be 25-30% of size and weight. High efficiency means that there will be more energy transferred from each surface element.

Almost every material is used as an heat transfer surface; there are no heavy frames, shells, tie rods, baffles and something like this, which are all necessary in a S&T exchanger, but it has no effect on heat transfer.

TEMPCO T-Plate B oil are efficient and compact, but will they last?

TEMPCO T-Plate B oil are among the strongest and most rugged heat exchangers available.

They are deep vacuum brazed with 99,9% pure copper. The plates are made of high grade type 316 stainless steel and they are solidly brazed along the edges, as well as on every contact point between the plates all over the entire heat transfer surface. This process produces a really strong heat exchanger which is rated for 30 bar/430 PSIG, even though special executions for higher pressure are available.

A firm construction with no loose parts guarantees high strenght and reliability also for rough applications.

I've heard that this type of heat exchanger fouls easily. What are the facts?

Fouling refers to fluids tendency to form a film or a scale on the heat transfer surface. Scaling increases pressure drop and insulate the heat transfer surface, preventing efficient heat transfer. Fouling occurs when there's low fluid velocity (laminar flow) and uneven flow distribution among passages and heat transfer surface.

The TEMPCO T-PLATE B OIL's unique design allows the heat exchanger to operate at extremely low velocities, while maintaining turbulent flow. The critical "Reynolds Number", where the flow switches from turbulent to laminar, is far much lower on a TEMPCO T-PLATE B OIL than other traditional exchangers, i.e. S&Ts.

Due to its internal geometry, that assures even fluid distribution, coupled with higher turbulence and 316 stainless steel hardness and smoothness, a TEMPCO T-PLATE B OIL is actually much less prone to foul than other S&T heat exchangers.

How much wide the product range is?

There are seven basic models. For each one of them, plates number can be varied to produce an almost unlimited heat exchangers variety.

For industrial applications, we have selected 25/30 standard sizes, that are kept in stock and ready to be immediately shipped.

Our flexibility in configuring the best plates number for a specified application means that we can supply the heat exchanger that exactly matches your requirements.

Parallel to the T-PLATE B OIL line, TEMPCO offers also a full Plate Heat Exchangers (PHE) line; there are 10 basic sizes with a plate variety for every possible condition.

Where can I use TEMPCO T-Plate B oil?

TEMPCO T-Plate B oil are suitable for almost any liquid to liquid application, including hydraulic oil, lube oil, glycol, steam, refrigerants and all types of water, except for sea water and highly corrosive media. For sea water, TEMPCO PHEs with titanium plates are recommended.

TEMPCO T-Plate B oil are used by leading OEMs as oil coolers, condensers, evaporators, batch heaters and for many other applications. They can be used as an integral component for heat recovery and energy management; they are therefore a legitimate alternative to air cooled equipment, where initial costs are high and heat recovery can be difficult. TEMPCO T-Plate B oil high efficiency allows their use in approach temperature as low as 2°C and heat recovery of over 90%.

Eventually, TEMPCO PHEs can be effectively used as aftercoolers and reheaters in compressed air systems.

Why should I change from my current heat exchanger to a TEMPCO's?

TEMPCO T-Plate B oil are the only heat exchangers that can have an impact on a total system design. Many components can be re-evaluated to lower costs and improved system design, efficiency and size not possible with previously available technology. In an age of energy and heat recovery and increasing demand for high quality and corrosion resistant materials, TEMPCO T-Plate B oil are the choice for lower initial costs, higher operating efficiency and longer service life.

TEMPCO T-Plate B oil Installation Instructions in Oil Cooling Applications

1) Define Oil/Water Circuit

When placing the exchanger with arrow sticker pointing upward, oil side is defined as left connections. Thus, water side will be on the right.

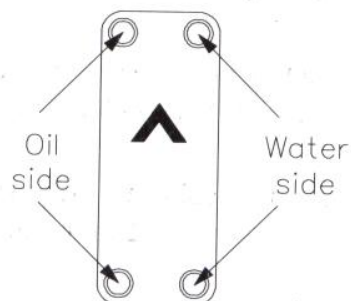

2) Connect the Oil/Water Inlet and Outlet to Achieve Counter Current Flow

- Oil inlet should be connected to the lower left connection.

- Oil outlet should be connected to the upper left connection.

- Water inlet should be connected to the upper right connection.

- Water outlet should be connected to the lower right connection.

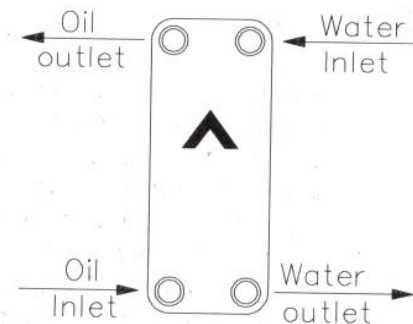

3) Positioning the Exchanger. How to Install

The exchanger can be mounted in any position. You should take into account if there would be a demand for draining any of the circuits.

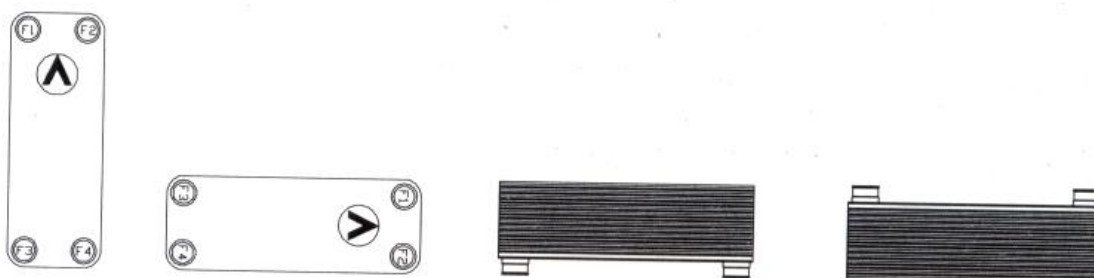

4) Mounting the Exchanger

Small units are mounted using a bracket around the exchanger.

Larger units, like B35/B45, are equipped with stud-bolts as standard. The stud-bolts are positioned on connection side.

5) Avoid Vibrations- or Pulsations-Caused Stress in Connections

Do not mount the exchanger into a rigid frame, but use Armaflex or something similar to make a soft and elastic installation.

All piping should be done in such a way that vibrations at the exchanger will be at minimum.

For hydraulic systems, where the exchanger is connected to the system return side, flexible pipes in the oil side are recommended.

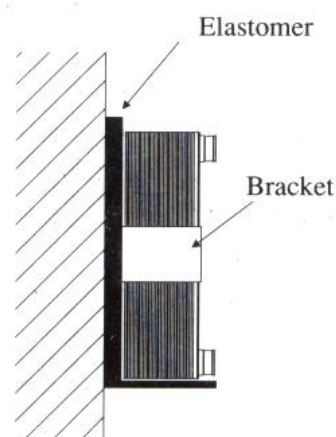

6) Cleaning

a. Determine if Fouling Has Occurred

Measuring heat exchanger entering and leaving temperature will indicate if fouling has occurred. Heat transfer surface fouling decreases the heat transfer, resulting in a temperature difference less than specified.

Another way to indicate fouling is by measuring pressure drop over the heat exchanger. Since fouling restricts passages and thus increases velocity, it will produce increased pressure drop.

When using these methods, make sure that water flow rate is as specified. Changes in flow rate of course effect also temperature changes and pressure drop.

b. Cleaning Method

If it has been decided that the heat exchanger requires cleaning, backflush with water will remove most of the soft particulate matter.

If fouling in form of hard deposit is present, circulate a weak acid through the exchanger, in reverse direction to the normal water flow. Use 5% phosphoric acid or, for frequent cleaning, 5% oxalic acid, or similar weak organic acid.

Afterwards, rinse with large amount of water to flush all acid from the heat exchanger before starting up the system again.

Never wait until the heat exchanger is completely plugged before attempting cleaning.



7) Filters or Strainers

When in the fluid there are particles that could block the exchanger, filters or strainers should be used. Particles up to diam. 1mm will not cause any problem.

TEMPCO T-Plate B oil Fouling Characteristics

Compared to other types of heat exchangers, TEMPCO T-Plate B oil have great differences in design, construction and performance.

Especially TEMPCO T-Plate B oil fouling characteristics are very much different than conventional types. Because of their unique construction, TEMPCO T-Plate B oil are much less prone to fouling than heat exchangers using tubular construction.

Standard fouling factors, written for conventional types, do not apply to TEMPCO T-Plate B oil.

Fouling factors:

Temperature, turbulence, velocity, flow distribution, surface finish and water quality all effect fouling within a heat exchanger.

Primary Fouling Causes

a. Laminar VS Turbulent Flow

You have a laminar flow when velocity in the flow channel is uneven with low velocity next to the heat transfer surface. When a fluid passes through a tube, higher velocity is at the center of the tube. The fluid velocity decreases the closer it gets to the tube wall, creating a stagnant film of low velocity fluid next to the tube wall. The tube wall has no turbulence to keep particles into suspension in the fluid. These particles are allowed to precipitate out and collect on the tube wall, causing heat transfer surface fouling.

Conventional types of heat exchangers are very sensitive to low velocities and easily get into the laminar region.

The opposite of laminar flow is turbulent flow.

Operating with turbulent flow is the best way to avoid fouling in heat exchangers. TEMPCO T-Plate B oil impart an high degree of turbulence in fluid and actually performs a scouring action to keep the heat transfer surface clean. This is accomplished by the TEMPCO T-PLATE B OIL unique design; as the fluid passes through the channel, it constantly changes direction, disturbing the boundary layer and insuring turbulent flow, even at extremely low velocities.

When using water, TEMPCO T-PLATE B OIL will always operate with turbulent flow.

b. Uneven Flow Distribution

Within conventional heat exchangers there can be low velocities areas resulting in laminar flow, due to uneven fluid distribution through the exchanger. These sections are prone to fouling.

Fouling starts at these low velocity areas and spread over the heat transfer surface.

Since all plates used in a TEMPCO T-Plate B oil are identical, channels too will be identical. This guarantees the same velocity in each parallel channel,

ensuring that the incoming fluid is equally distributed among the channels.
No low velocity areas are created where fouling can start to build up.

c. Poor Distribution Over Heat Transfer Surface

It's of great importance to have well distributed flow over the heat transfer surface to maintain uniform velocity. The TEMPSCO T-Plate B oil unique flow pattern distributes the flow evenly as it enters each flow channel, providing uniform velocity gradients over the entire heat transfer surface.

d. Heat Transfer Surface Quality

The material used in TEMPSCO T-Plate B oil is AISI-316 stainless steel. The smooth surface of this material has a positive effect in minimizing fouling. Rough surfaces are known to encourage fouling by collecting particulate matter.

In applications where a cooling tower or another open system are used, cooling water will be rich in oxygen. This can cause corrosion of materials such as carbon steel, used in conventional heat exchangers.

This corrosion is usually in the form of iron oxide scale on the carbon steel surface; however, loose iron oxide can be deposited elsewhere as well.

Stainless steel used in TEMPSCO T-Plate B oil, while not completely immune to corrosion under certain conditions, is not subject to uniform corrosion which causes fouling problems.

e. Scaling

Scaling is the deposit of hard or soft substances which are dissolved in water on heat transfer surface.

Most common scale types are calcium carbonate and calcium sulphate which, due to inverse solubility effect tend to form a deposit when water is heated above a certain temperature. Tendency for this kind of fouling increases with increased temperature, concentration, pH.

Studies have shown that an high degree of turbulence and a small hydraulic diameter, such as in TEMPSCO T-Plate B oil, have beneficial effects on this type of fouling. Cooling water proper maintenance and treatment, especially in cooling towers, greatly reduces scaling risk.

TEMPSCO T-PLATE B OIL Cleaning

a. Determine if Fouling Has Occurred

Measuring heat exchanger entering and leaving temperature will indicate if fouling has occurred. Heat transfer surface fouling decreases the heat transfer, resulting in a temperature difference less than specified.

Another way to indicate fouling is by measuring pressure drop over the heat exchanger. Since fouling restricts passages and thus increases velocity, it will produce increased pressure drop.

When using these methods, make sure that water flow rate is as specified. Changes in flow rate of course effect also temperature changes and pressure drop.

b. Cleaning Method

If it has been decided that the heat exchanger requires cleaning, backflush with water will remove most of the soft particulate matter.

If fouling in form of hard deposit is present, circulate a weak acid through the exchanger, in reverse direction to the normal water flow. Use 5% phosphoric acid or, for frequent cleaning, 5% oxalic acid, or similar weak organic acid.

Afterwards, rinse with large amount of water to flush all acid from the heat exchanger before starting up the system again.

Never wait until the heat exchanger is completely plugged before attempting cleaning.

Conclusions

- a. In a TEMPCO T-PLATE B OIL, fouling is minimized, compared to other heat exchangers types, due to the following unique characteristics:
 - turbulent flow is maintained also at extremely low flow velocities;
 - excellent fluid distribution through the exchanger and over the heat transfer surface eliminates low velocity areas where fouling can start;
 - heat exchangers plates smooth surface quality minimizes the opportunity for particles to adhere to the surface.
 - use of stainless steel for heat exchanger plate minimizes the risk of corrosion fouling

- b. In open systems the use of a strainer is recommended to prevent debris from entering any heat exchanger.

- c. If necessary, TEMPCO T-Plate B oil are easily cleaned in place, by backflushing with water or a weak acid solution.