

T CRIO

Cryogenic cooling package units



T CRIO is a new package unit developed by Tempco in partnership with Polaris used for cryogenic cooling of process fluids.

The system uses liquid nitrogen as coolant. Used nitrogen can be recovered in form of gas and then recycled for other uses in the customer network.

The unit can use different types of anti-freeze fluids (e.g. methanol, toluene, diathermic fluids, etc...), depending on operating temperature range.

An heating/cooling option is also available on request.

OPERATION

System operation is completely automatic and user friendly. The unit is equipped with a smart control system for settings and state logging. For remote access in case of need, a telemetry system is included.

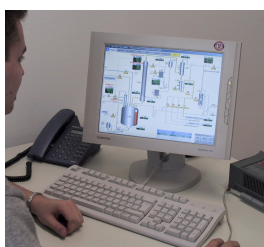

TYPICAL CONFIGURATION

- circulation pump
- expansion/storage tank
- heat exchanger
- temperature control system
- safety instruments
- PLC based control system
- PC supervision

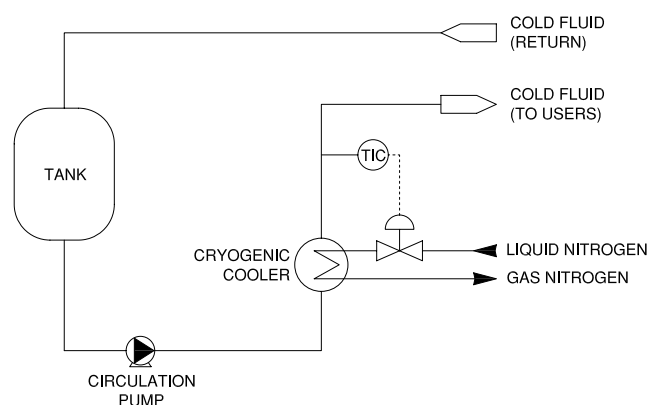

T CRIO



MAIN FEATURES

- simplified utility management
- high flexibility
- low investment cost, well suitable for batch processes (eg. bulk pharmaceutical industry)
- low maintenance costs
- FDA compliant
- high heat transfer performances
- compact layout

T CRIO SPECIFICATIONS

unit type	cooling capacity [kcal/h (KW)]	pump flow rate [m ³ /h]	operating temperature range [°C]	dimensions [mm]
T CRIO 5	25000 (30)	5	-100 / +120	1400 x 1400 x 1750h
T CRIO 10	50000 (60)	10	-100 / +120	1700 x 1700 x 2100h
T CRIO 20	100000 (120)	20	-100 / +120	1850 x 1850 x 2100h

other design temperature available upon request

KNOW-HOW BY



T Crio system is based on process design and know-how by Polaris Srl, a company specialized in cryogenic applications worldwide.

(www.polarisengineering.com)